

## Precision Current Source is Software-Programmable

*A shunt regulator provides a constant reference voltage across a digital potentiometer that, in conjunction with an op amp and transistor, forms a software-programmable, voltage-controlled current source.*

With the addition of a few inexpensive miniature components, the hard-wired, voltage-controlled current source of yesterday becomes a software-programmable voltage-controlled current source (**Figure 1**).

A digital potentiometer (U1) in conjunction with a precision op amp (U2) sets current through the pass transistor ( $I_{SET}$ ), and a shunt regulator (U3) provides a constant reference voltage across the digital pot. By operating in its linear region, the transistor controls load current in response to the applied gate voltage. Each incremental step of the digital pot increases or decreases the voltage  $V_{IN+}$  at the op amp's noninverting input. Thus, the pot's wiper voltage ( $V_{IN+}$ ) varies with respect to the reference voltage, which in turn remains stable with respect to the supply rail:

$$V_{IN+} = \frac{V_{REF} [R_{TOTAL(DP)} / (\text{total no. of steps})]}{R_{TOTAL(DP)}}$$

Many types of digital potentiometers are currently available, and the interface to these devices (besides the hard-wired type) can be one, two, or three wires. U1, for example, has a 3-wire SPI interface, and provides an end-to-end resistance of  $50k\Omega$  with 256 incremental settings. Thus, each increment of the digital pot changes  $V_{IN+}$  by:

$$V_{IN+} = \frac{3V (50k\Omega / 256)}{50k} = 11.72mV$$

Op amp U2 regulates current through the pass transistor, and the digital pot sets current through the  $R_{SENSE}$  resistor. The voltage across  $R_{SENSE}$  determines current through the pass transistor ( $I_{SET}$ ):

$$I_{SET} = (V_{CC} - V_{IN+}) / R_{SENSE}$$

The circuit can provide any current level for which the external components ( $R_{SENSE}$  and the

pass transistor) can handle the associated power dissipation ( $P = IV$ ). Because the ratio setting of digital potentiometers is very good (the typical ratiometric resistor tempco is 5ppm/° C), precision and stability for the current source depends primarily on the precision and stability of U3 and  $R_{\text{SENSE}}$  combined.

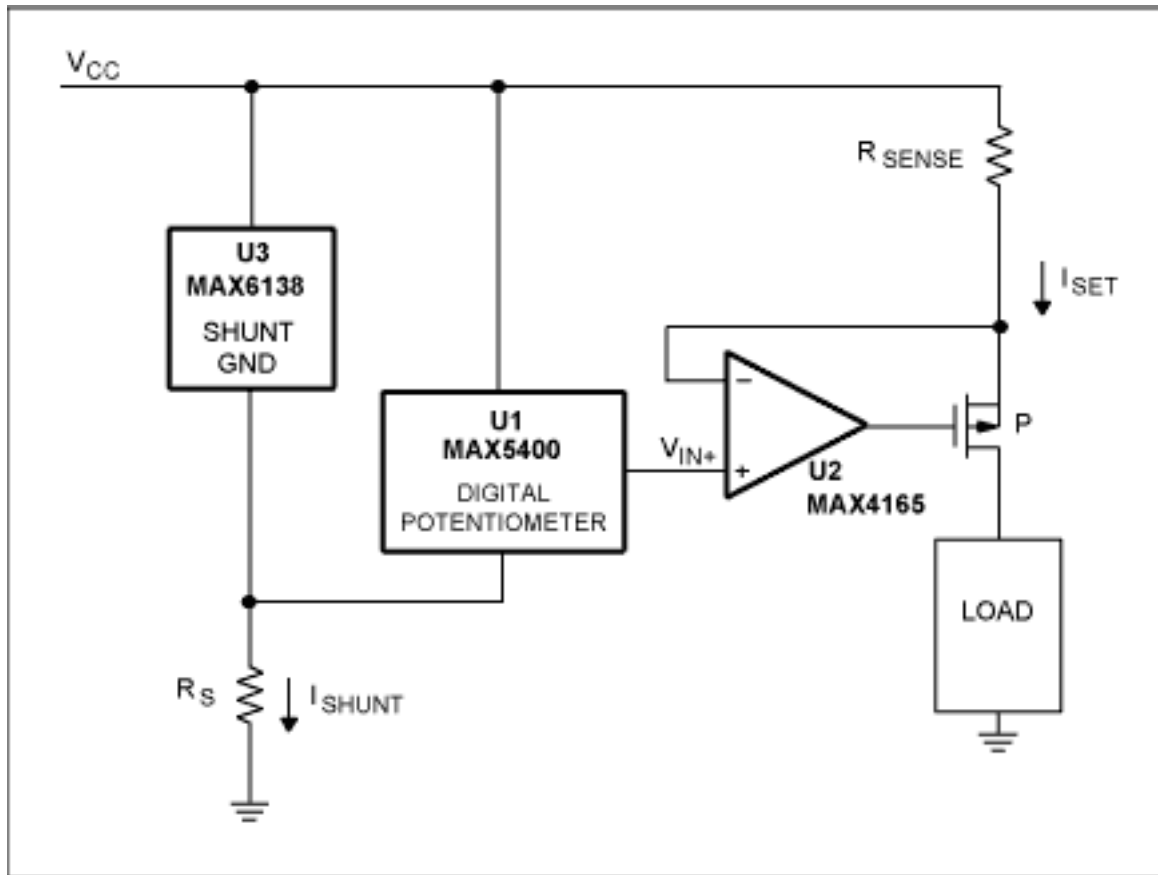

Figure 1. This software-programmable, precision current source applies current to the load in 256 equal increments.

A similar version of this article appeared in the December 17, 2004 issue of *EDN* magazine.

### More Information

MAX4165: [QuickView](#) -- [Full \(PDF\) Data Sheet](#) -- [Free Samples](#)

MAX5400: [QuickView](#) -- [Full \(PDF\) Data Sheet](#) -- [Free Samples](#)

MAX6138: [QuickView](#) -- [Full \(PDF\) Data Sheet](#) -- [Free Samples](#)